

AUDIO AND CONSUMER ELECTRONICS / PORTABLE AUDIO / PORTABLE SPEAKERS

MALIBU-310

10" PORTABLE SPEAKER



- ✓ Great power and sound quality.
- ✓ 1 UHF hand-held wireless microphone.
- ✓ Multiple playback options and karaoke functions
- ✓ Easy transport with trolley
- ✓ Long-life rechargeable battery.



+ Info:
<https://fonestar.com/MALIBU-310>

ESPECIALLY RECOMMENDED IN:



Sports facilities



Hospitality



Education

DESCRIPTION

10" portable speaker. 100 W max., 20 W RMS. 1 UHF hand-held wireless microphone. Bluetooth/USB/microSD/FM/LINE player and microphone audio recorder.

TECHNICAL CHARACTERISTICS

FEATURES	<p>Portable speaker.</p> <p>1 x UHF hand-held wireless microphone (650 MHz).</p> <p>Bluetooth/USB/microSD/FM/LINE player and microphone audio recorder.</p> <p>Bluetooth 5.3 receiver.</p> <p>Karaoke function with Voice Canceller, priority, microphone echo control and independent volume control of music and microphones.</p> <p>TWS function for pairing two speakers via Bluetooth and transmitting USB, microSD, FM or LINE IN.</p> <p>Wired microphone input.</p> <p>Rechargeable Li-ion battery.</p> <p>BASS REFLEX bass reinforcement.</p> <p>Remote control for the player.</p> <p>Trolley transport cart.</p> <p>Hole in the base for 35 mm tube.</p>
POWER	<p>100 W maximum</p> <p>20 W RMS</p>
SPEAKERS	<p>1 x 10" woofer</p> <p>1 x 1" tweeter</p>
INPUTS	<p>1 x micro, 6.3 mm jack, 4,700 Ohm 33 mV</p> <p>1 x stereo line, 3.5 mm jack, 10,000 Ohm 549 mV</p>
CONTROLS	<p>Microphone volume with echo.</p> <p>Player volume with bass and treble control.</p> <p>Player with source selection, playback control, recording, TWS (transmits USB, microSD, FM or LINE IN), voice remover, voice priority, playback mode and equalization.</p> <p>Low battery indicator.</p> <p>Battery charge indicator.</p>



+ Info:

<https://fonestar.com/MALIBU-310>

POWER SUPPLY	110-240 V AC, 24.4 W Battery Li-ion 11.1 V, 2200 mAh Autonomy with rechargeable battery: 8 h* Battery charging time: 3 h *Battery life at 50% of the volume. Depending on the type of music and volume, the battery life may be reduced. Works while recharging Wireless microphone: 2 x LR6-AA batteries Remote control: 2 x LR03-AAA batteries
DIMENSIONS	310 x 490 x 260 mm depth
WEIGHT	5.70 kg
OPTIONAL	FAL-M10: carrying bag



+ Info:

<https://fonestar.com/MALIBU-310>

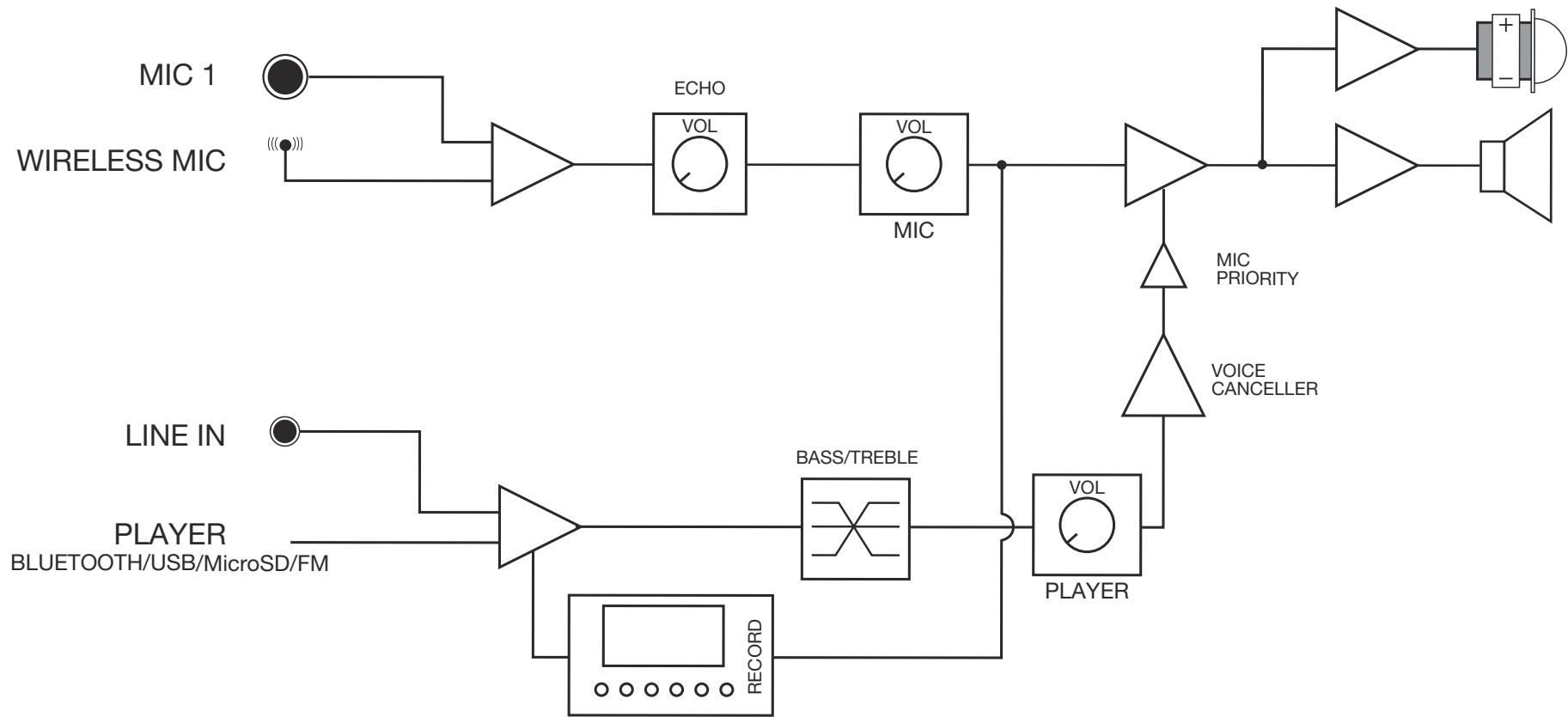

Product:
MALIBU-310 Block Diagram
 Date: 2025-01-10